



Development of an alpha fast-slow coincidence counter for analysis of ^{223}Ra and ^{224}Ra in seawater

Chau Thi Nhu Quynh, Pham Ngoc Tuan, Tran Anh Khoi and Tuong Thi Thu Huong

Nuclear Research Institute, 01 Nguyen Tu Luc, Dalat, Lam Dong

Email: quynhchaupr@gmail.com

Abstract: An alpha fast-slow coincidence counter has been designed and manufactured for measuring the low alpha activities of ^{223}Ra and ^{224}Ra in the seawater. In this work, Radium from the seawater was absorbed onto a column of MnO_2 coated fiber (Mn fiber). The short-lived Rn daughters of ^{223}Ra and ^{224}Ra which recoil from the Mn fiber are swept into a scintillation detector where alpha decays of Rn and Po occur. Signals from the detector are sent to a delayed coincidence circuit which discriminates decays of the ^{224}Ra daughters, ^{220}Rn and ^{216}Po , from decays of the ^{223}Ra daughters, ^{219}Rn and ^{215}Po .

Keywords: *Low alpha counting system, analysis of ^{223}Ra and ^{224}Ra .*

I. INTRODUCTION

Giffin et al. (1963) developed a highly sensitive system for the measurement of ^{219}Rn and ^{220}Rn by determining the delayed coincidence counting of the rare gas products of ^{231}Pa [1]. Based on the Giffin's design, a similar system has been developed in the Dalat Nuclear Research Institute in order to measure ^{223}Ra and ^{224}Ra in coastal water.

The counting system functioned based on the detection of alpha particles from the decaying scheme ^{223}Ra , ^{224}Ra and daughters shown in Fig. 2.

The delayed circuits were established in order to open and close the gates following the decay times of Rn, about four half-lives of Po [2].

By employing the method of conceptual analysis, an alpha fast-slow coincidence spectrometer has been designed and manufactured in the Dalat Nuclear Research Institute. This system is used for the low alpha activity analysis of ^{223}Ra and ^{224}Ra in seawater.

II. DESIGN AND MANUFACTURE

The block diagram of the alpha fast-slow coincidence counter was shown in Fig. 1.

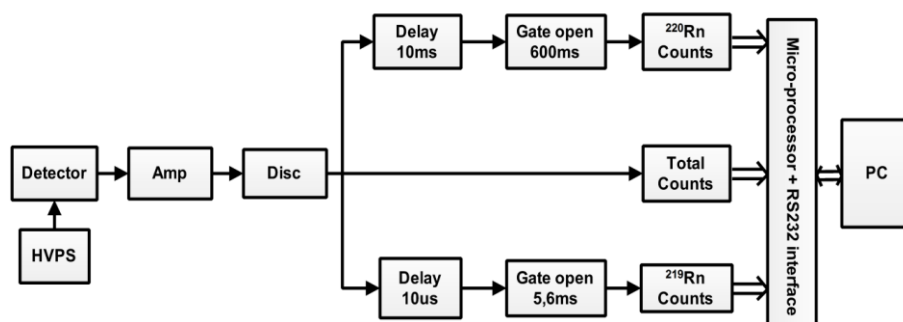

Fig. 1. Schematic diagram of the delayed coincidence circuit.

The detector was fabricated from a sealed plexiglass chamber. The silver-activated zinc sulfide ZnS(Ag) is used as a scintillator [3]. It was coated on the internal surface of the chamber wall in order to optimize the efficiency of detecting an emitted radiation. The volume of the chamber is 1.7 L. A scintillation detector coupled to a photomultiplier tube (PMT) R877 of Hamamatsu [4]. The signals from PMT were sent to an amplifier and analyzed by a delayed coincidence circuit which includes of a buffer/timer, microcontrollers and connected to the PC via the RS-232 interface. The above

circuits are designed using the Xilinx ISE 10.1 toolkits and programmed by C++Builder language [5-7].

When a Rn nuclear decays, an alpha particle is emitted. If this alpha particle interacts with ZnS(Ag) of sealed chamber, it will create photons. The PMT obtained the photons and formed electronic pulses. The output signals must be shaped and amplified by a shaping amplifier and then converted into logic pulses. A counter system analyzes the decay time of each pair of radon-polonium following the decay scheme shown in Fig. 2. [NuDat 2.7]

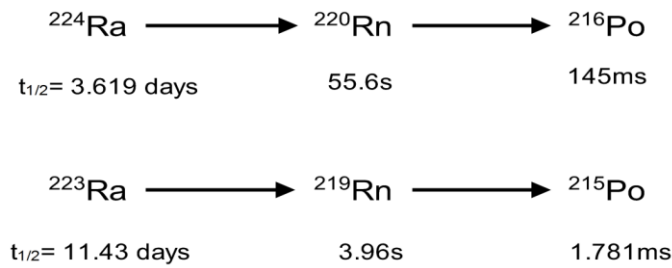

Fig. 2. Simplified decay scheme of ${}^{223}\text{Ra}$ and ${}^{224}\text{Ra}$.

The delayed coincidence circuit contains three separated counter channels. The slow channel 1 (Ch#1) is to measure ${}^{224}\text{Ra}$ during the gate time of 600ms ($4T_{1/2}$ of ${}^{216}\text{Po}$); the fast channel 2 (Ch#2) is to determine ${}^{223}\text{Ra}$ during the

gate time of 5.6ms ($3T_{1/2}$ of ${}^{215}\text{Po}$) and the channel 3 (Ch#3) is used to obtain total counts during the measuring time. A block diagram of ${}^{220}\text{Rn}$ channel and a timing diagram for 3 counter channels are presented in Fig. 3 and Fig. 4.

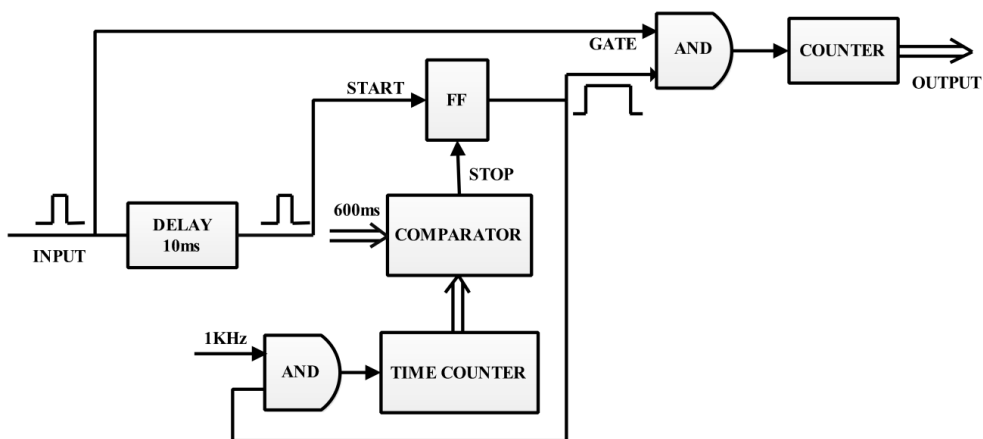

Fig. 3. Block diagram for ${}^{220}\text{Rn}$ channel.

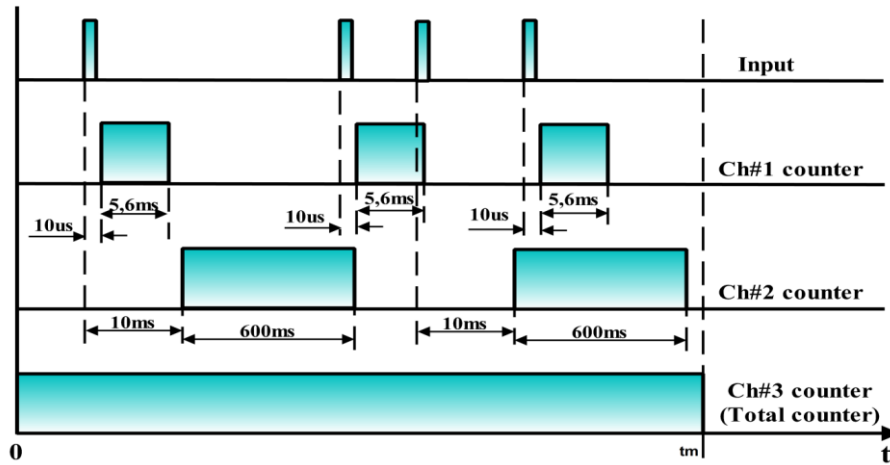

Fig. 4. Timing diagram for 3 counter channels.

The alpha particle detected in the scintillation chamber produces a signal and registered by a delayed coincidence channels (see Figure 1). For Ch#1, the signal is delayed for 0.15ms to allow the circuit to stabilize. The signal opens a gate during the time interval of 5.6ms. Any second count detected in this period time is recorded in the ^{219}Rn channel. The count itself is most likely due to ^{215}Po decay, but, it would have been unrecorded if a decay of ^{219}Rn had not opened the gate within the prior 5.6ms.

The production of decay from ^{219}Rn to ^{215}Po is also fed to the Ch#2 and delayed for 10ms. At that time, the ^{220}Rn circuit opens for 600ms. If a signal occurs while this gate is opened, it is recorded in the ^{220}Rn channel [2].

The final adjustment must be made to the ^{220}Rn data due to ^{219}Rn and its daughter. If two ^{219}Rn decays occur while the ^{220}Rn window is open, the second ^{219}Rn decay of ^{215}Po will be recorded in the ^{220}Rn channel [2].

We designed a complete count system shown in Fig. 5.



Fig. 5. A complete count system.

III. TESTING MEASUREMENT

Set up for the experiment is shown in Figure 6. The exponential decay pulse with frequency approximate $986 \pm 1(\text{Hz})$ from the DB2

generator was used as an input pulse for the amplifier discriminator. The TTL logic pulse from its output was counted by three counter channels during the gate times as shown in Fig. 4.

When the system starts measuring, Ch#1 and Ch#2 wait for a first input pulse of $10\mu\text{s}$ to open the gates. Ch#1 measured all events during the gate time of 5.6ms while Ch#2

obtained the events at the gate time of 600ms. The circuits were repeated continuously until stopping measurement. Total counter channel measured all events in the preset time t_m .

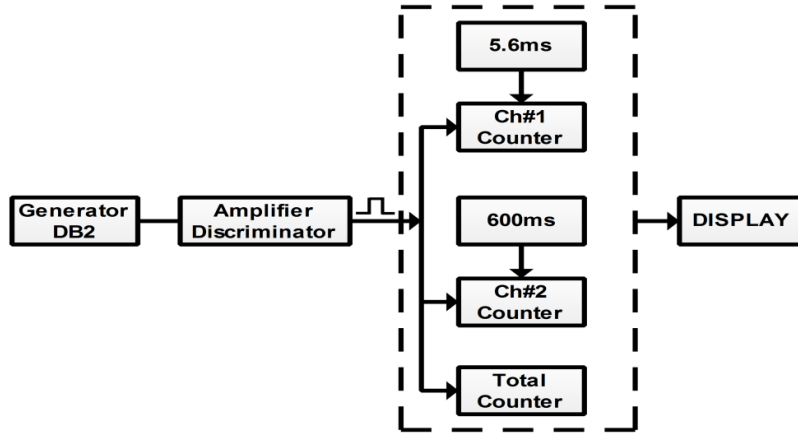

Fig. 6. Schematic diagram of testing setup.

Estimated count (EC) of each channel could be calculated by the following semi empirical formula:

$$EC = \left[\left(\frac{t_m}{t_G + t_w} \right) * t_G * CR \right] - \left(\frac{t_m}{t_G + t_w} \right)$$

where:

- t_m : preset time (100s);
- t_w : waiting time ($10\mu\text{s}$ for ^{219}Rn and 10ms for ^{220}Rn);
- t_G : gate time;
- CR : count rate, $CR = \text{Total count}/t_m$;

- Total count get on total counter channel.

In this test measurement, the gate time for ^{219}Rn is 5.6ms while the gate time for ^{220}Rn is changed from 600ms to 900ms in order to evaluate the counts detected from each channel. The obtained results showed that the differences between measured and estimated values are 3.5% and 0.3% for ^{219}Rn and ^{220}Rn , respectively. The standard deviation is less than 0.2% for different measurements. The measured and estimated counts obtained from each counter channel are presented in Table I.

Table I. Comparison of measured and estimated counts of ^{219}Rn and ^{220}Rn .

Gate time ^{219}Rn (ms)	Gate time ^{220}Rn (ms)	Total count	^{219}Rn			^{220}Rn		
			Measured counts	Estimate counts	Relative deviation (%)	Measured counts	Estimated counts	Relative deviation (%)
5.6	600	98761	82300	79484	3.54	97270	96962	0.30
5.6	700	98773	82310	79496	3.54	97492	97227	0.26
5.6	800	98558	82131	79285	3.59	97437	97205	0.23
5.6	900	98518	82098	79245	3.60	97516	97314	0.20
Mean		98653	82210	79378		97429	97177	
Standard deviation (%)		0.14	0.13	0.17		0.11	0.16	

III. CONCLUSIONS

The alpha coincidence counter with three separated counter channels has been designed and fabricated successfully in the Dalat Nuclear Research Institute. The gate times were set of 5.6ms and 600ms for fast and slow channels, respectively. This system has been used for analysis of ^{223}Ra and ^{224}Ra in seawater.

This alpha three channels counter has a compact design and digital signal process. This is a new trend to design electronic devices because of a simple circuit design by using FPGA.

REFERENCES

- [1]. Giffin, C., A. Kaufman, and W. Broecker, Delayed coincidence counter for the assay of actinon and thoron, *J. Geophys. Res.*, 68(6), 1749–1757, 1963.
- [2]. Moore, W. S., and R. Arnold, Measurement of ^{223}Ra and ^{224}Ra in coastal waters using a delayed coincidence counter, *J. Geophys. Res.*, 101(C1), 1321–1329, 1996.
- [3]. EJ-440 ZnS:Ag Phosphor sheet from ELJEN Technology; www.eljentechnology.com
- [4]. Photomultiplier tubes R877 from Hamamatsu corporation company datasheets; www.hamamatsu.com
- [5]. Xilinx, KPCSM3 PicoBlaze Processor Reference Guide, Embedded Development Kit EDK 10.1.
- [6]. Spartan-3E FPGA Starter Kit Board User Guide; Website: www.xilinx.com
- [7]. ISE Design Suite 10.1 Release Notes and Installation Guide; Website: www.xilinx.com.